

KOMATSU

PC
55MR

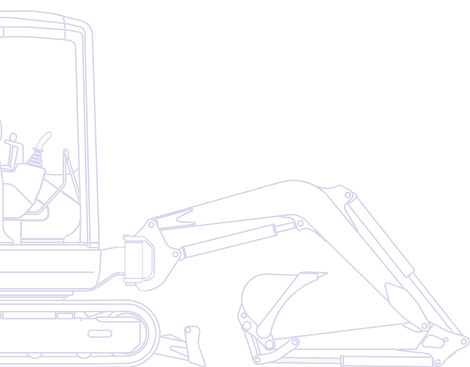

Mini-Excavator **PC55MR-3**



ENGINE POWER
29,5 kW / 39,6 HP @ 2.400 rpm

OPERATING WEIGHT
5.160 - 5.350 kg

BUCKET CAPACITY
0,07 - 0,175 m³

Walk-Around

The new PC55MR-3 compact mini-excavator is the result of the competence and technology that Komatsu has acquired over the past 80 years. It was designed and developed with constant attention to the needs of customers from all over the world. The end product is a user-friendly machine with top-class performances.

Total versatility

- Customised configurations
- Standard 1 or 2 way auxiliary line for attachments
- Ideal for a wide range of applications

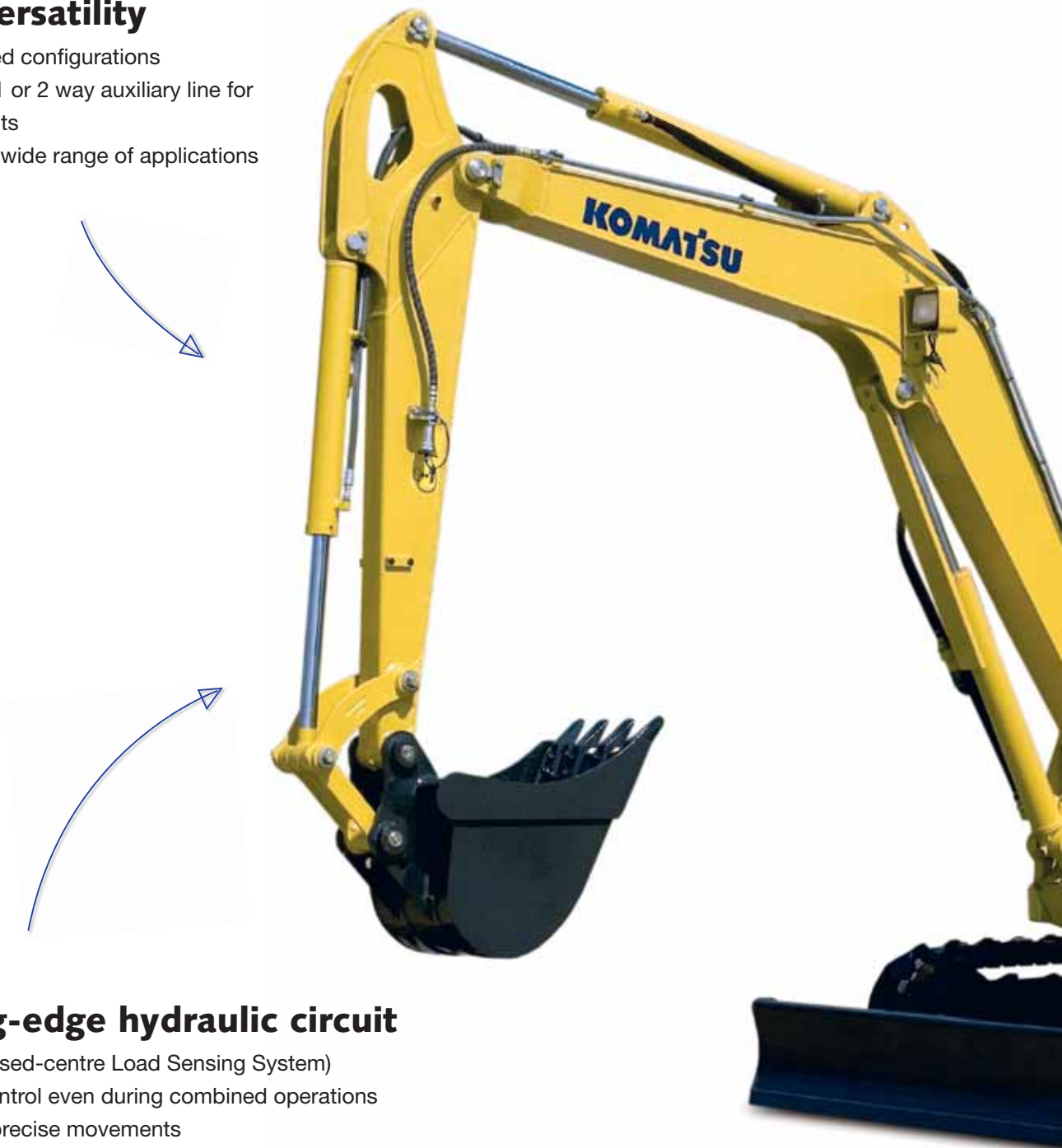

Cutting-edge hydraulic circuit

- CLSS (Closed-centre Load Sensing System)
- Perfect control even during combined operations
- Fast and precise movements

PC55MR-3

ENGINE POWER
29,5 kW / 39,6 HP @ 2.400 rpm

OPERATING WEIGHT
5.160 - 5.350 kg

BUCKET CAPACITY
0,07 - 0,175 m³

First-class operator comfort

- Spacious working environment
- Sliding door
- Pressure Proportional Control (PPC) servo-controls



Outstanding performances

- Optimal power and digging speed
- Superior stability and safety in any conditions
- Fast and precise movements



Easy maintenance

- Quick access to all daily inspection points
- Tilting cab for maintenance jobs
- Extended 500-hour service interval

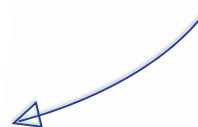

KOMTRAX

Komatsu Satellite
Monitoring System

Outstanding Performances



Work in tight spaces

The new short-tail PC55MR-3 delivers optimal power and digging speed, even in confined spaces where traditional machines can't work: yards, road works, demolition sites, sewers, etc. Sturdy and very stable, it guarantees maximum safety and offers complete operator confidence in any working conditions.

Automatic down-shift

This feature automatically adjusts the hydraulic travel motor for the job at hand: maximum displacement for faster movement, or minimum displacement for high drawbar pull. This process requires no attention from the operator. The two-speed tracking is operated via a switch on the blade lever.

X-frame

The new X-frame ensures maximum stress resistance and optimal stress distribution. Its shape makes the machine a lot more rigid and reliable. In addition, it facilitates the regular undercarriage cleaning operations and the spoils removal process.



Cutting-Edge Hydraulic Circuit

Komatsu CLSS

The CLSS (Closed-centre Load Sensing System) hydraulic circuit guarantees power, speed and perfect control to all movements, including simultaneous ones. The combination of the variable displacement pump and of CLSS allows operators to perform all

required movements with maximum efficiency, regardless of the load or rpm. The unique CLSS characteristics are perfectly complemented by the hydraulic servo-controls, which are, by far, the easiest to use and that allow extremely precise manoeuvres with minimal effort.



First-Class Operator Comfort



An optimal work environment

Despite its compact size, the PC55MR-3 offers unequalled comfort. The spacious cab was developed with exceptional care to details, and the work environment is quiet and comfortable. Special attention is given to the operator: ergonomic and dedicated PPC controls, and, in option, an efficient air conditioning and ventilation system to guarantee optimal thermal comfort. Last, but not least, the upper rail sliding door makes getting in and out of the machine very easy and safe in any situation.





Customisation

Many configurations are available, so you can choose the perfect machine for the job: long or short arm, cab or canopy, rubber, steel or road liner shoes. The 1 / 2 way auxiliary hydraulic circuit allows the use of a wide range of working tools such as a hammer, a clamshell bucket, an auger etc.

To further enhance the operator's comfort, new optional fingertip controls that act on the first auxiliary hydraulic line now offer improved versatility and controllability and guarantee maximum precision and minimum finger fatigue when working with attachments. The auxiliary oil flow rate can also easily be adjusted through the monitor panel, directly from the operator's seat.



Easy Serviceability

Tilting cab

The wide opening engine bonnets provide a quick access to daily inspection points. The fuel and the hydraulic oil tanks are located under the side bonnet, in a safe and easy-to-reach position. In addition, the cab easily tilts back for major maintenance tasks.

Easier repairs

ORFS hydraulic face seal connectors and DT electrical connectors enhance the machine's reliability and make repairs faster and easier. High durability bushings and a 500 hours engine oil change interval further lower operating costs.



Rear bonnets for quick engine checks, simple inspections, cleaning of the radiators and easy access to the battery



Front bonnet: fuel tank refilling

Specifications

ENGINE

The new generation engine has been developed to comply with the strictest emission controls.

Model	Komatsu 4D88E-6
Type	emissionised 4-cycle diesel engine
Displacement.....	2.189 cm ³
Bore × stroke.....	88 × 90 mm
No. of cylinders	4
Engine power	
at rated engine speed	2.400 rpm
ISO 14396	29,5 kW / 39,6 HP
ISO 9249 (net engine power)	28,5 kW / 38,2 HP
Max. torque/engine speed	137 Nm/1.440 rpm
Cooling system.....	water
Air filter type	dry
Starter motor	electric motor with pre-heating air system for cold climate

OPERATING WEIGHT

Operating weight with standard bucket, fully serviced, +75 kg operator (ISO 6016).	
Operating weight with cab and rubber shoes	5.280 kg
Operating weight with cab and steel shoes	5.350 kg

HYDRAULIC SYSTEM

Type	Komatsu CLSS
Main pump	2 × variable displacement pump
Max. pump flow.....	53,5 × 2 + 33,8 ltr/min
Max. operating pressure	26,5 MPa (265 bar)
Hydraulic motors:	
Travel.....	2 × variable displacement
Swing.....	1 × fixed displacement
Hydraulic cylinders (bore × stroke):	
Boom	90 × 696 mm
Arm	85 × 733 mm
Bucket.....	75 × 580 mm
Boom swing.....	95 × 630 mm
Blade.....	110 × 140 mm
Bucket digging force (ISO 6015)	3.900 daN (3.980 kg)
Arm crowd force (ISO 6015):	
1.640 mm arm.....	2.392 daN (2.440 kg)
2.000 mm arm.....	2.226 daN (2.270 kg)
The digging equipment is fully controlled by PPC servo-controls. All movements are stopped by lifting the safety levers on the tilting case.	

TRANSMISSION

Type	2 speed hydrostatic transmission, controlled and steered by means of two levers and two pedals
Hydraulic motors	2 × axial pistons
Reduction system.....	planetary gear
Max. drawbar pull.....	4.200 daN (4.280 kgf)
Travel speed	2,8 - 4,6 km/h

SWING SYSTEM

The rotation is operated by means of an orbital hydraulic motor. Single ball-bearing ring with internal, induction hardened toothring. Centralised lubrication of the unit.	
Swing speed.....	9,0 rpm

BLADE

Type	electro-welded, single unit structure
Width × height	1.960 × 355 mm
Max. lifting above ground level	430 mm
Max. depth below ground level	330 mm

UNDERCARRIAGE

Central lower X-frame and carriage frame with boxed section.	
Track rollers (each side).....	4
Shoe width	400 mm
Ground pressure (standard).....	0,25 kg/cm ²

ELECTRIC SYSTEM

Voltage.....	12 V
Battery	72 Ah
Alternator.....	40 A
Starter motor	2,3 kW

SERVICE CAPACITIES

Fuel tank	65 ltr
Radiator and system	8,5 ltr
Engine oil (refill)	7,5 ltr
Hydraulic system.....	55 ltr

ENVIRONMENT

Vibration levels (EN 12096:1997)*	
Hand/arm.....	≤ 2,5 m/s ² (uncertainty K = 1,2 m/s ²)
Body	≤ 0,5 m/s ² (uncertainty K = 0,2 m/s ²)
* for the purpose of risk assessment under directive 2002/44/EC, please refer to ISO/TR 25398:2006.	

BUCKET RANGE

Width mm	Capacity m ³ (ISO 7451)	Weight kg	No. of teeth
300	0,07	75	2
400	0,1	90	3
500	0,125	100	4
600	0,15	115	5
700	0,175	125	5

Dimensions & Working Range

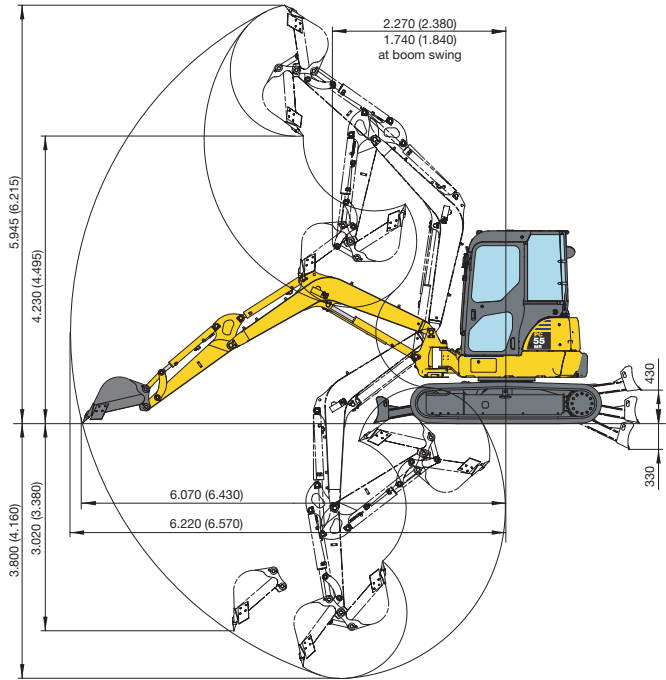
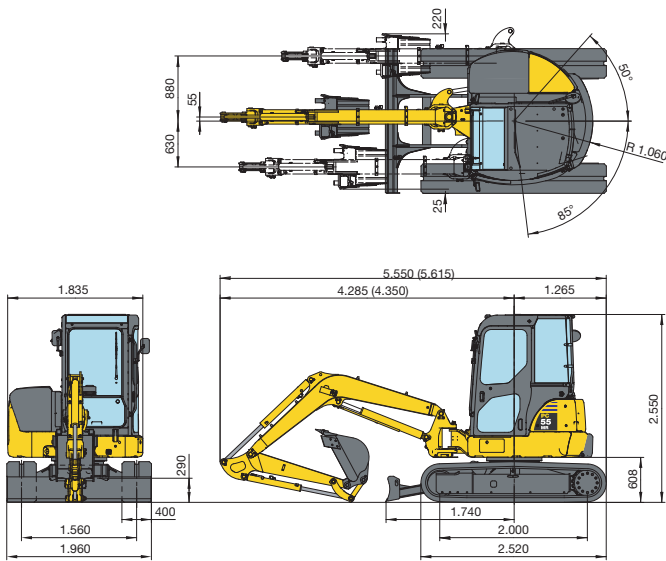

Cab, rubber shoes, blade down

A - Distance from machine's center B - Height at bucket pin

ARM LENGTH 1.640 mm

B \ A	2 m		3 m		4 m		Max. outreach	
	Front	360°	Front	360°	Front	360°	Front	360°
4 m	-	-	-	-	(*)790	780	(*)835	670
3 m	-	-	-	-	(*)845	775	(*)850	520
2 m	-	-	(*)1.435	1.180	(*)1.050	745	(*)885	460
1 m	-	-	(*)2.030	1.085	(*)1.285	705	(*)930	440
0 m	-	-	(*)2.260	1.040	(*)1.435	680	(*)985	455
-1 m	(*)2.790	2.025	(*)2.170	1.040	(*)1.415	670	(*)1.050	520
-2 m	-	-	-	-	-	-	-	-

Unit: kgf

Cab, rubber shoes, blade up

A - Distance from machine's center B - Height at bucket pin

ARM LENGTH 1.640 mm

B \ A	2 m		3 m		4 m		Max. outreach	
	Front	360°	Front	360°	Front	360°	Front	360°
4 m	-	-	-	-	(*)790	780	(*)835	670
3 m	-	-	-	-	(*)845	775	780	520
2 m	-	-	(*)1.435	1.180	(*)1.050	745	695	460
1 m	-	-	1.665	1.085	1.065	705	670	440
0 m	-	-	1.620	1.040	1.035	680	695	455
-1 m	(*)2.790	2.025	1.615	1.040	1.025	670	795	520
-2 m	-	-	-	-	-	-	-	-

Unit: kgf

ARM LENGTH 2.000 mm

B \ A	2 m		3 m		4 m		Max. outreach	
	Front	360°	Front	360°	Front	360°	Front	360°
4 m	-	-	-	-	(*)625	(*)625	(*)730	565
3 m	-	-	-	-	(*)700	(*)700	(*)750	450
2 m	-	-	(*)1.160	(*)1.160	(*)915	750	(*)785	400
1 m	-	-	(*)1.815	1.095	(*)1.175	705	(*)825	385
0 m	(*)1.285	(*)1.285	(*)2.180	1.030	(*)1.375	670	(*)875	395
-1 m	(*)2.365	1.975	(*)2.205	1.015	(*)1.420	655	(*)935	445
-2 m	-	-	-	-	-	-	-	-

Unit: kgf

ARM LENGTH 2.000 mm

B \ A	2 m		3 m		4 m		Max. outreach	
	Front	360°	Front	360°	Front	360°	Front	360°
4 m	-	-	-	-	(*)625	(*)625	(*)730	565
3 m	-	-	-	-	(*)700	(*)700	685	450
2 m	-	-	(*)1.160	(*)1.160	(*)915	750	620	400
1 m	-	-	1.680	1.095	1.065	705	595	385
0 m	(*)1.285	(*)1.285	1.605	1.030	1.025	670	615	395
-1 m	(*)2.365	1.975	1.590	1.015	1.010	655	690	445
-2 m	-	-	-	-	-	-	-	-

Unit: kgf

NOTE:

Ratings are based on ISO standard 10567. Rated loads do not exceed 87% of hydraulic lift capacity or 75% of tipping load.

- The values marked with an asterisk (*) are limited by the hydraulic capacities.
- Calculations are based on the machine resting on a uniform and firm surface.
- The lifting point is a hypothetical hook placed behind the bucket.

Mini-Excavator

PC55MR-3

Standard Equipment

- ROPS (ISO 3471) / FOPS (ISO 10262) tilting cab with heating
- Sliding door
- 400 mm rubber shoes
- 1.640 mm digging arm
- Two speeds with "Automatic Shift Down"
- 1 / 2 way auxiliary hydraulic circuit up to the arm
- Blade
- Adjustable suspension seat
- Lifting cylinder guard
- Working light on boom
- 2 rear-view mirrors
- Travel acoustic alarm
- KOMTRAX™ - Komatsu satellite monitoring system

Optional Equipment

- ROPS (ISO 3471) / FOPS (ISO 10262) canopy
- 400 mm steel shoes
- 400 mm road liners
- 2.000 mm digging arm
- Air conditioning
- Bucket range (300 - 700 mm)
- 1.400 mm ditch cleaning bucket
- Boom, arm and blade safety valves
- Overload warning device
- Rotating beacon
- Cab/canopy working lights
- Additional cab rear working light
- Auto deceleration
- Proportional controls for attachment on joystick
- Komatsu mechanical quick-coupler
- Buckets with Kmax teeth

Your Komatsu partner:

KOMATSU

**Komatsu Europe
International NV**
Mechelsesteenweg 586
B-1800 VILVOORDE (BELGIUM)
Tel. +32-2-255 24 11
Fax +32-2-252 19 81
www.komatsu.eu