

KOMATSU

Utility

SK
1020-5



SK1020-5

SK1020-5

SKID STEER LOADER

NET POWER
SAE J1349
51,1 kW

OPERATING WEIGHT
3.420 kg

OPERATING CAPACITY
905 kg

SK1020-5 SKID STEER LOADER

Power and ease-of-use make the SK1020-5 the ideal machine for the most difficult jobs. This compact loader has been designed with the operator in mind, considering its ease-of-operation, simple maintenance, low emissions and excellent comfort. These make it a pleasure to own and operate, as well as an indispensable asset.

Hydraulic Servocontrols

The PPC servocontrols are simple to use. The one on the right controls the movements of the arm and the bucket, while the one on the left controls the travel functions. These allow the machine to be manoeuvred with the finest precision and minimal effort.

Engine

The KOMATSU engine, compliant with the European EURO 2 emission standards, guarantees the power and torque required for every work situation. In addition, the low noise levels and vibrations improve the working conditions for the operator, as well as everyone else near the machine.

Hydraulic System

The CLSS hydraulic system (closed load sensing system) guarantees progressive control, precision, and smoothness in all movements. Moreover, it combines power and speed that always perfectly match the requirements of the work at hand. Two two-stage axial piston pumps allow this compact loader to travel at 16 km/h in second gear (standard).

Comfort

From the ergonomics of the controls to the space in the cab, from the adjustable seat to the low operating noise, everything has been designed to create a safe, comfortable environment for the operator. This makes work as easy and effortless as possible.





Safety

A sophisticated system of sensors on the safety bars on the seat disables all movements if unauthorised manoeuvres are attempted. This is done by automatically activating a brake on the transmission. The ROPS-FOPS cab, excellent dynamic stability, and 360° visibility allow the operator to work in complete tranquillity at all times.

Instrumentation

The newly designed, KOMATSU-patented dashboard, mounted on the safety bar, is always visible to the operator.

Versatility

The characteristics of this compact loader allow it to be used for a broad range of applications. For everyday use at building sites, in industrial environments, or at ports, the SK1020-5 replaces manual labour with incomparable versatility. The high operating load (905 kg) and the auxiliary hydraulic system allow the use of a vast range of equipment, further expanding job application possibilities. This is assisted by the possibility to fit a hydraulic-control quick hitch.

Super Flow

The *Super Flow* system increases the flow of available oil to the equipment, and features a drainage system and electrical connections. The joysticks and the proportional pedal allow control over all system functions. A second hydraulic circuit is available for equipment that requires simultaneous movements.

Super Flow circuit flow-rate: 130 (120*) ℓ /min

Second circuit flow-rate: 80 (10*) ℓ /min

*Flow-rate for the combined operation of the two circuits.



Maintenance

A simple opening of the engine bonnet makes refilling and regular checks easy. The tilting radiators can be easily reached by opening the rear door. A single lock for the bonnet and door protects all service and refill points.

- Pins with extended greasing intervals (250 hours)
- Battery with charge gauge
- Air filter with safety cartridge
- Removable tank
- See-through gas oil filter
- Environmentally-friendly draining systems.



Tilting Cab

The combined tilting of the cab, engine bonnet and footboard (patented system) ensures complete access to all of the components. This allows extraordinary maintenance operations to be performed from several positions.



SPECIFICATIONS



ENGINE

A new generation of engine developed to comply with the stricter emission controls (EURO 2).

Model.....Komatsu 4D98E-2NFE
 Type.....diesel engine, 4 in line cylinders
 Bore x stroke.....98 x 110 mm
 N° of cylinders.....4

Combustion.....direct injection
 Aspiration.....natural
 Max power.....52,6 kW

Rated power:
 (SAE J1349).....51,1 kW/69,5 HP - 2.500 rpm
 (80/1269/EC).....51,1 kW/46,2 HP - 2.500 rpm
 Max Torque.....235 Nm - 1.600 rpm

Cooling system.....water
 Air filter.....dry with safety element
 Starting system.....electric motor with pre-heating air system for cold climate



OPERATING WEIGHT

Operating weight of machine with standard bucket, full tank of fuel and a 80 kg operator (ISO 6016)3.420 kg



HYDRAULIC SYSTEM

Type.....Komatsu CLSS (Closed Load Sensing System)
 Pump.....gear
 Max flow.....80 l/min
 Max pressure.....210 bar
 Control valve.....3 elements fully Servo-controlled
 Front equipment hydraulic system "SUPER FLOW" (Optional):

Max flow.....130 l/min
 Max pressure.....210 bar
 Control valve.....3 or 4 elements



CONTROLS

Proportional Servo-controls (PPC). The left hand lever controls the machine movements, the right one controls the working equipment. The PPC pedal controls the auxiliary circuit for attachments. A safety system neutralises all operations when the safety bars are risen or the operator is not seated.



TRANSMISSION

Type.....hydrostatic
 Pumps.....2 x variable displacement with 2 stage and APC system

Motors.....2 x axial pistons with two speeds
 Final transmission with heavy duty type roller chains immersed in oil bath are always oil connected with the four driving wheels.
 Speeds: - Working.....10,5 km/h
 - Travel.....16 km/h
 Oil immersed discs for both parking and working breaks with negative action and automatic insertion.



TYRES

Standard.....12-16.5 8PR
 Optional.....12-16.5 8PR (narrow tread)



ELECTRIC SYSTEM

Rated voltage.....12 V
 Battery.....100 Ah
 Alternator.....40 A



REFILLS

Hydraulic system.....50 l
 Fuel.....73 l
 Hydraulic transmission (chains).....16 + 16 l
 Engine oil.....12,5 l



LOADER

Operating load (ISO 5998).....905 kg
 Tipping load (ISO 8313).....1.810 kg
 Standard bucket capacity (ISO 7546).....0,45 m3
 Bucket breakout force (ISO 8313).....2.242 daN (2.290 kg)
 Max loading height with forks.....2.910 mm
 Max reach with forks.....2.210 mm

DIMENSIONS

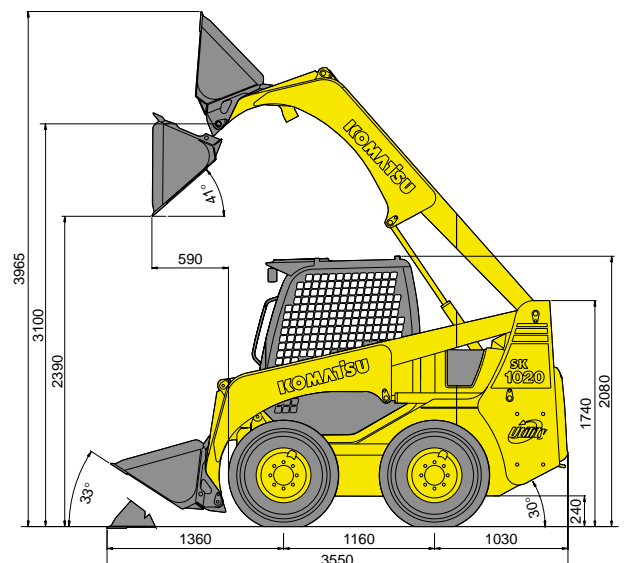
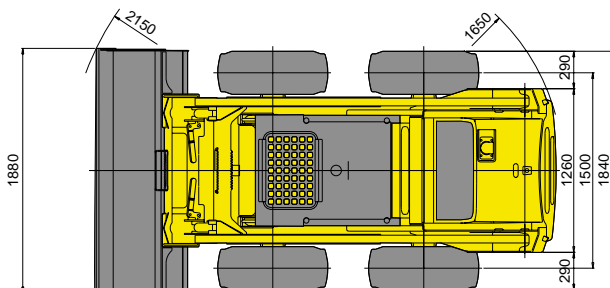

SK1020-5 SKID STEER LOADER

STANDARD EQUIPMENT

- | | | |
|--|--|--|
| <ul style="list-style-type: none"> • ROPS-FOPS tilting cab • Adjustable seat with safety belts • Safety bars • 2-speed transmission • 2 front working lights • Instrumentation including: counter - LCD fuel gauge - LCD engine water temperature gauge - safety device warning lights: operator on board, | <ul style="list-style-type: none"> safety bars lowered - other warning lights: clogged air filter, engine oil pressure, alternator, hydraulic oil filter • Automatic parking and working brakes • Horn • Accelerator pedal • Self-levelling bucket • Auxiliary hydraulic circuit for | <ul style="list-style-type: none"> attachments • 12V power outlet outside • 12-16.5 8PR tyres • Universal quick hitch • 1.880 mm bucket with or without teeth |
|--|--|--|

OPTIONAL EQUIPMENT

- | | | |
|---|--|---|
| <ul style="list-style-type: none"> • Bucket float • SUPER FLOW version with 3-element valve (fitted with drain line and electric connection) • SUPER FLOW version with 4-element valve (fitted with drain line and electric connection), with additional auxiliary hydraulic circuit for multi-function equipment • Road homologation • Adjustable seat with shock absorber and safety belts • 12-16.5 8PR wheels with narrow track | <ul style="list-style-type: none"> • Narrow bucket (1.730 mm) with or without teeth • Blade under teeth • Bolted blade (instead of teeth) • 2 rear working lights • Rotating beacon • Back-up alarm • Rear-view mirrors • Pallet fork • Lifting hooks • Fixed or sliding side windows • 12V power outlet inside • FOPS class 2 cab • Closed cab with side windows, door | <ul style="list-style-type: none"> (with wiper) and heating • Backhoe pre-setting • Cold climate version • Modular 126 kg rear counterweight (6 pieces) |
|---|--|---|

KOMATSU

Komatsu Utility Europe

Komatsu Utility Europe
 Head Office
 via Atheste 4
 35042 Este (Padova) Italy
 Tel. +39 0429 616111
 Fax +39 0429 601000
 www.equipmentcentral.com
 utility@komatsu.it



COMPANY WITH
 ENVIRONMENTAL MANAGEMENT
 SYSTEM CERTIFIED BY DNV
ISO 14001